

# PERFORMANCE DATA

FEEDER (TIER 3)

BMF 2500

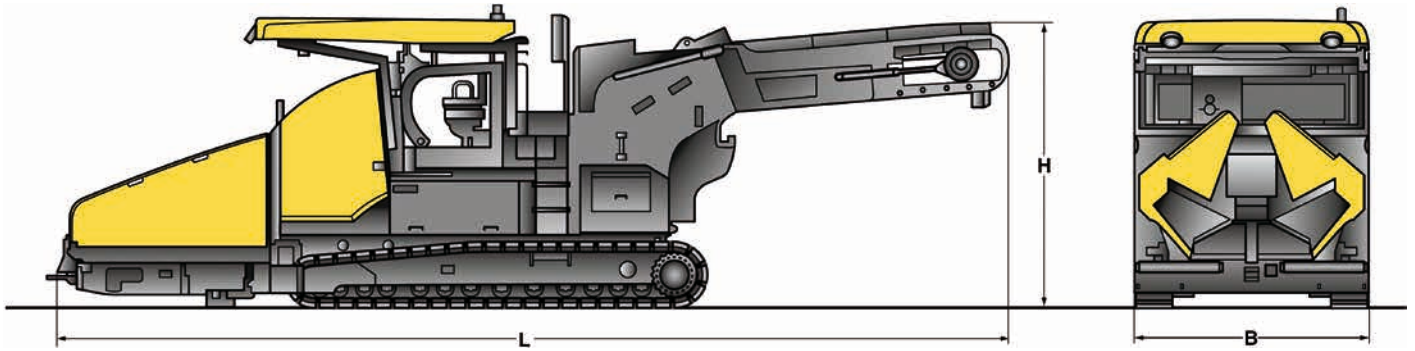



**Transport dimensions in m**

	<b>Length</b>	<b>Width</b>	<b>Height</b>
<b>BMF 2500 S</b>	9.25	2.55	3.10
<b>BMF 2500 M</b>	10.26	2.55	3.10
<b>BMF 2500 S OC 650</b>	15.30	2.55	3.10

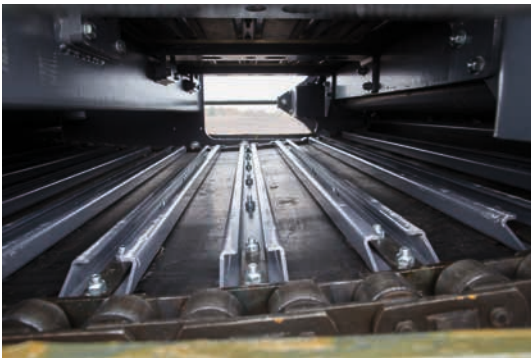

Work reliably – the chain-reinforced conveyor belt prevents downtime.



Flexible in use – the optionally available swivel belt with 6.5 m (OC 650) for BMF 2500 S.



Prevent demixing – 1.20 m width ensures smooth material transport.



Everything in view – the lift platform offers the best overview.

## Technical data

## BOMAG BMF 2500

### Weights CECE

BMF 2500 S .....	kg	20000
BMF 2500 M .....	kg	21000
BMF 2500 S OC 650 .....	kg	24500

### Dimensions

Transport length BMF 2500 S .....	mm	9250
BMF 2500 M .....	mm	10260
BMF 2500 S OC 650 .....	mm	15300
Transport width BMF 2500 S .....	mm	2550
BMF 2500 M .....	mm	2550
BMF 2500 S OC 650 .....	mm	2550
Transport height .....	mm	3100
Approach angle .....	°	10

### Travel characteristics

Travel speed .....	km/h	0-4
Working speed .....	m/min	0-25 variable

### Drive

Engine manufacturer .....		Cummins
Type .....		QSB6.7-C260
Exhaust classification .....		Stage III a / T4f
Cooling system .....		Fluid
Number of cylinders .....		6
Displacement .....	cm <sup>3</sup>	6700
Power .....	kW / HP	164/225
Rated speed .....	rpm	2200

### Track-chain chassis

Overall length .....	mm	3950
Width .....	mm	320

### Hopper

Capacity .....	m <sup>3</sup> / t	7/15
Width (wings open) .....	mm	3350
Width (wings closed) .....	mm	2550
Length .....	mm	2250
Filling height (middle) .....	mm	580

### Conveyor belt

Type .....		Rubber band, mounted on two roller chains, with metal cross braces
Speed .....		Infinitely adjustable
Width .....	mm	1200
Feed height BM 2500 S / BMF 2500 M .....	mm	2180 mm (with hydraulic height adjustment 2560 mm)
Feed height BM 2500 S OC 650 .....	mm	1300-4350 (hydr. height adjustment)
Capacity .....	t/h	up to 4000

### Filling capacities

Fuel .....	l	360
Hydraulic oil .....	l	200

### Electric system

Voltage .....	V	24
---------------	---	----

Technical modifications reserved. Machines may be shown with optional accessories. Actual machine weight depends on the respective configuration.

## Standard equipment

### Operator's platform

- 2 drivers' seats, swivelling and rotating
- Protection, dashboard
- Adjustable dashboard
- Hydraulically foldable roof
- Digital machine management display
- Weather protection roof
- Height-adjustable lift platform

### Tractor

- Individual control of the hopper wings
- Chain scrapers
- Rubber track pads
- Hydr. hopper front gate
- Cleaning kit
- Slewing belt pre-fitting (BMF 2500 S)
- Central lubrication for conveyor belt

### Conveyor belt

- Scraper for conveyor belt
- Automatic cleaning system for conveyor belt
- LED lighting for swivel belt
- Hydraulic height adjustment for conveyor belt

### Assistance systems

- On-board tools
- Automatic distance control
- Automatic loading assistant
- Laptop station
- LED roof lighting

### Miscellaneous

- 7 halogen working lights
- Flashing beacon
- Reversing buzzer
- 2 x 24 V sockets
- 2 x 12 V sockets
- Storage compartments

## Optional equipment

### Operator's platform

- Weather protection for platform
- Comfort seat with seat heating
- Comfort seat with joystick

### Tractor

- Special paintwork
- Biodegradable hydraulic oil
- Camera system (compatible with swivel belt)
- Stop light system
- FLEXMIX Basis (2 conical augers in the hopper)

### Conveyor belt

- Swivel belt OC 650  
(only for model BMF 2500 S incl. cover)

### Assistance systems

- Automatic steering system (max. 14.0 M)
- Automatic steering system (max. 10.0 M)

### Miscellaneous

- BOMAG TELEMATIC fleet management
- Light balloon (24 V, 250 W)
- Fire extinguisher
- Safety package with coming home function
- Engine compartment lighting

