

TECHNICAL DATA

TRACTOR MOUNTED SPREADER

BS 3, BS 5

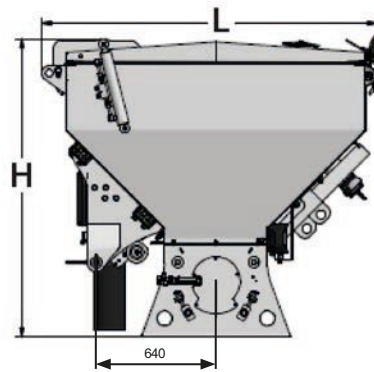

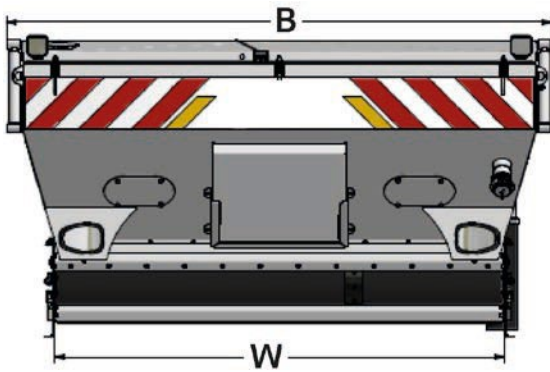

Standard equipment

- Speed-dependent dosing
- Radar sensor for speed detection
- Compressed air filling from front
- Variable working width
- Large hydraulic flap for big bag/excavator/silo filling
- 4.3" display for machine control from the tractor cab

Optional equipment

- Weighing plate for dosage control
- Filter System „Bag filter“
- Camera monitoring
- Traffic lighting
- Additional working lights
- Custom color

Dimensions in mm

	B	H	L	W
BS 3	2922	1598	1795	2412
BS 5	2922	2048	1795	2412

Technical data

Type.....	
Capacity.....	m ³
Output*.....	kg/m ²
Working width.....	m
Weight (empty).....	kg
Weight (full).....	kg

**BOMAG
BS 3**

Tractor mounted
3,5
3 to 50
0,8 / 1,6 / 2,4
1.290
4.290

**BOMAG
BS 5**

Tractor mounted
5,5
3 to 50
0,8 / 1,6 / 2,4
1.405
6.405

Tractor requirements

Tractor lifting device.....	
Recommended travel drive.....	
Lifting capacity.....	t
2 double-acting valves for hydr. Supply.....	l/min
(Unpressurized return line recommended)	

Three-point category 2 and 3	
stepless 0 to V max	
5	7
50	50

* Crawling gear required

